

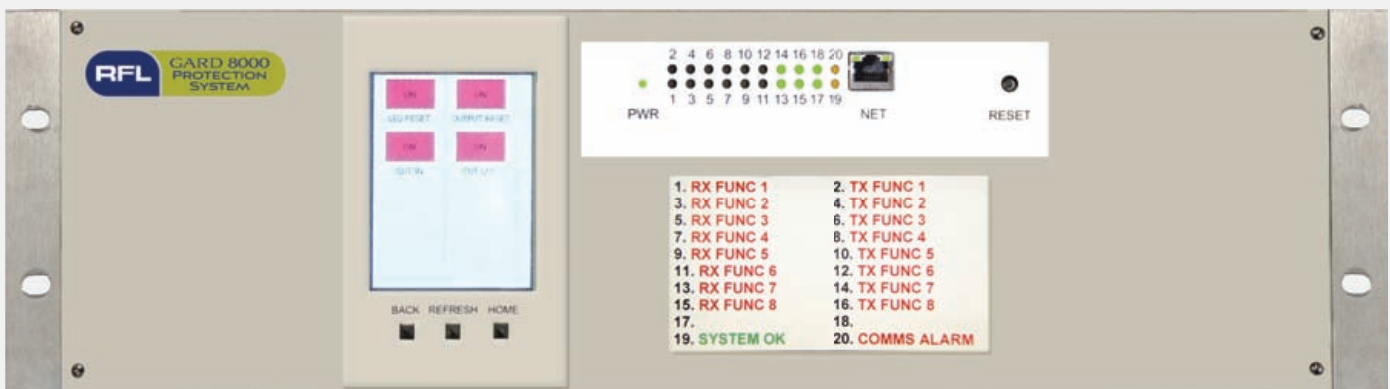

SOLUTIONS FOR AN EVOLVING WORLD

RFL GARD 8000 TELEPROTECTION CHANNEL



© 2014 RFL

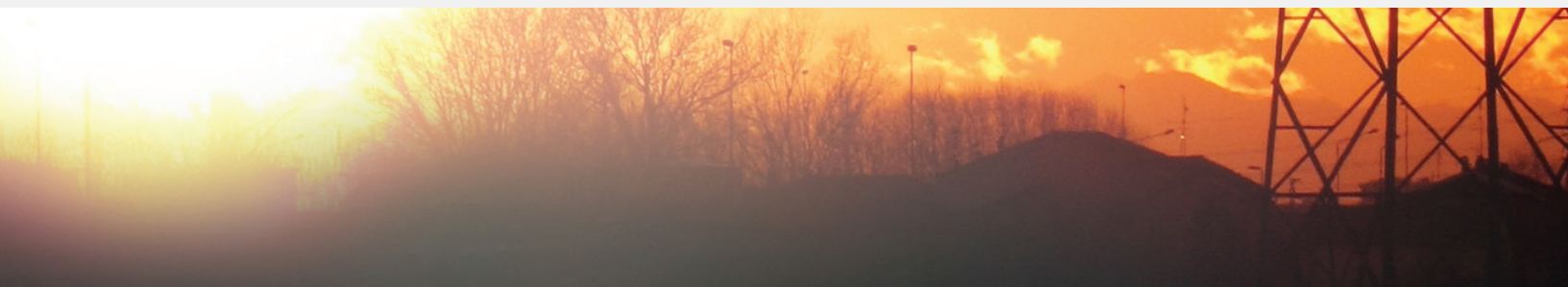



© 2018 RFL. All rights reserved.

Your world is changing and so are we.

At RFL, we know your needs change much faster than your infrastructure. Our comprehensive line of solutions meets you wherever you are to help you bridge the gap from yesterday to tomorrow.

We aren't just engineering products. We are continuously innovating to give legacy equipment the advantage of today's technologies. Our highly adaptable solutions offer more features for more flexibility and a custom fit for your specific needs.

When we deliver, we also deliver our reputation. So when you open that box, you're opening a custom-engineered solution, factory-tested and ready for deployment.

And as long as you own that equipment, you own the attention of RFL. We see you as our partner and we want to ensure that our solution is working for you - now and over the long haul. RFL - delivering solutions that work. Period.





Teleprotection Channel

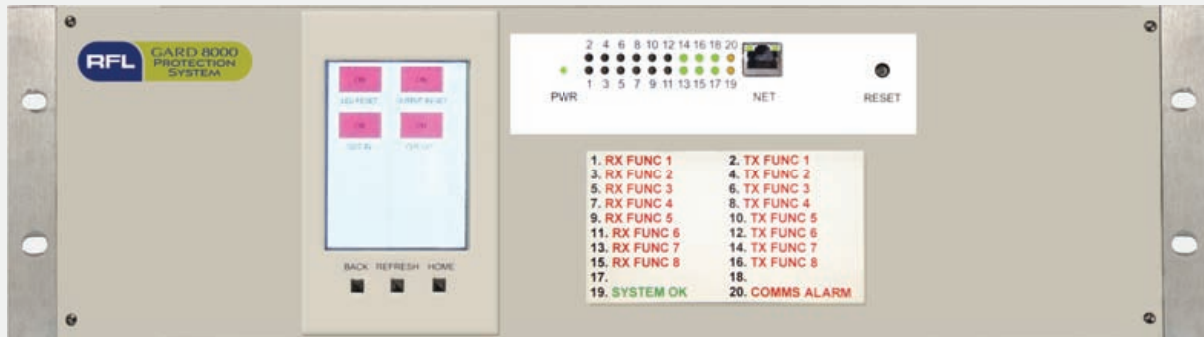

System Features

- One product for all your digital, analog, and IEC 61850 teleprotection needs
- User defined logic and alarms for your specific applications
- Straight forward web browser user interface for settings and diagnostics; no proprietary application program required
- Supports SNTP (Simple Network Time Protocol)
- Optional, built-in GPS receiver provides accurate time tags
- Complete address and checkback testing
- DNP3, Level 2 compliant
- SNMPV2 Compliant
- IEC-61850 HMI standard
- Full system redundancy option available
- Optional pass-through 56/64kbs or 19.2kbs Mirrored Bit multiplexer relaying channels
- Additional plug-in protection modules such as RFL Distance and Current Differential Relays
- Supports NERC/FERC security standards

Teleprotection Features

- Digital system comes standard with 32 functions for tripping applications
- 4 Channels available on Audio Teleprotection Module
- 16 point bidirectional status & RS-232 data option available for analog TPC systems
- Optional IEC-61850 LAN tripping module
- System can accommodate multiple teleprotectionschemes in one chassis
- Analog and digital systems can be mixed in one chassis
- 1+1 and other redundant back-up schemes are easily supported
- 96 bit high capacity 56/64kpbs status transfer module option
- Complete range of digital and fiber optic interfaces including C37.94
- Remote interrogation of far end with analog and digital systems
- 10 Year Warranty

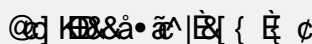

GARD 8000 Teleprotection



System Description

The GARD 8000 Teleprotection channel is a revolutionary product platform that provides the user with a fully programmable system that can be used for Direct Transfer Trip, Permissive Transfer Trip, Blocking, and Unblocking applications. The product is unique in that the same platform is used for analogue, digital, and IEC 61850 LAN tripping applications. The base system is the digital platform that can be used to transmit and receive up to 32 functions in groups of 8. Each block of 8 commands is transmitted over a 56/64kbs data channel, these data channels can be any of the supported digital interfaces. In essence the user is provided a teleprotection channel that has four conventional 8-function teleprotection systems built-in for the price of one.

Based on the RFL 9745 Teleprotection channel, the GARD 8000 Teleprotection system carries relaying communications to the next level. The system uses fully programmable logic and settings that can be uploaded or downloaded using the built-in TCPIP (electrical or optical) or RS-232 interface. Communicating with the system is done with either a laptop PC using Web Browser, or with the optional built-in color TSD (touch screen device) that communicates with the GARD. The GARD 8000 has a built-in web server that contains all of the user settings. No special or proprietary software is required to access the product. A most unique feature is that the user manual and customer system and application drawings are stored in the GARD 8000 in Adobe pdf format and are easily accessible from the GARD 8000 web browser.

The GARD 8000 is available in a 3U chassis (5.25") which can support up to two additional analog or digital teleprotection function modules, or a 6U chassis (10.50") which can support up to eight analog or digital teleprotection function modules. Other GARD 8000 communications or protection modules can be used in the chassis if desired. Redundant controller and power supplies are available as options for applications where ultra reliable systems are required.

Applications

The GARD 8000 Teleprotection communications interface can be configured for audio, digital, fiber optic, or Ethernet LAN per the IEC 61850 standard. It is well suited for standard and non-standard pilot protection schemes such as:

- Permissive Transfer Trip
- Direct Transfer Trip
- Blocking and Unblocking
- Remedial Action schemes (96 status bits over a 56/64 kbps channel)
- Transfer trip plus bi-directional status
- Transfer trip with slow speed RS-232 data

The GARD 8000 can have up to twelve communications interfaces which allow the product to be used over all communications media available. The following digital interfaces are available for the GARD 8000.

- RS-449/X.21/V.35 (DB37 connector), this multi-protocol interface is standard with all systems (Analog and Digital)
- G.703 (DB15 connector)
- T1/E1 (DB15 connector)
- E1 (BNC connector 50/75 Ohm)
- C37.94 short haul fiber, 820nm and 1300 nm LED (ST connector), provides up to 12 channels for teleprotection functions
- 1300nm LED SM/MM (ST connector)
- 1300nm LASER SM (ST connector)
- 1550nm LASER SM (ST connector)
- IEC 61850 TCPIP interface

A GARD 8000 can be configured with many functional teleprotection modules, each with their own communications interfaces, an example of this is shown in Figure 1. These communication channels can be configured for primary and back-up communications channels. For example 8 digital teleprotection commands from Functional Module #1 can be transmitted over communications interface A via direct fiber optic link, and another 8 digital teleprotection commands from Functional Module #2 can be transmitted over communications interface B via a digital microwave. This configuration capability also allows a user to consolidate the number of teleprotection boxes used for an application. A primary and a back-up scheme can be configured with one GARD 8000, each of the protection schemes can be configured with back-up communications channels and also redundant power supplies and processors. This configuration will have a higher overall MTBF than two separate conventional protection channels and will cost less.

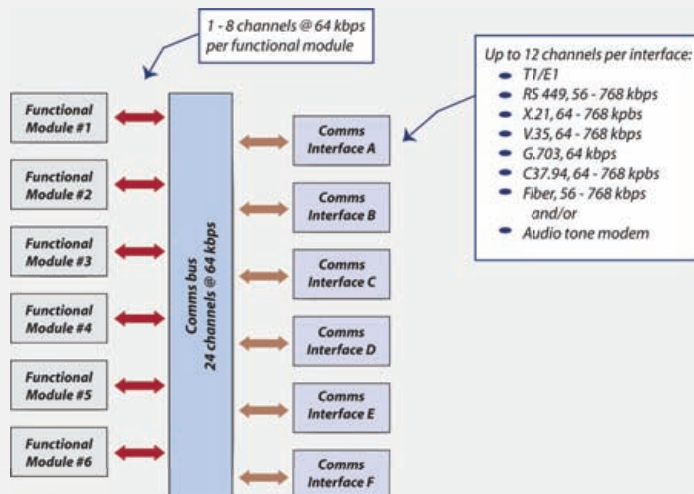
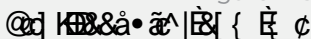

Figure 1. System Architecture





Diagnostics and Testing

Diagnostic information is available and easily accessible with the GARD 8000 Teleprotection unit. RFL's diagnostic package takes the guesswork out of power system fault analysis and evaluating communications system performance during the fault-clearing process. The GARD 8000 Teleprotection provides the following standard features:

- Two TCPIP ports (electrical or fiber)
- One RS-232 port for local or remote access
- 600 Sequence-of-events records
- Internal real-time system clock
- IRIG-B Clock sync input
- Current status of all system parameters
- Diagnostic information about the remote end
- Checkback testing either locally or remotely initiated
- Automatic checkback and addressing
- Channel propagation delay measured and reported

BIT #	Status	Trigger Label	Logic	Changed State
0	Inactive	TRIG0	LN0	No
1	Inactive	TRIG1	LN1	No
2	Inactive	TRIG2	LN2	No
3	Inactive	TRIG3	LN3	No
4	Inactive	TRIG4	LN4	No
5	Inactive	TRIG5	LN5	No
6	Inactive	TRIG6	LN6	No
7	Inactive	TRIG7	LN7	No
8	Inactive	TRIG8	LN8	No
9	Inactive	TRIG9	LN9	No
10	Inactive	TRIG10	LN10	No
11	Inactive	TRIG11	LN11	No
12	Inactive	TRIG12	LN12	No

Figure 3. System of Events Details

Detail#	Date	Time	Trigger Label	Status
Detail#01	04/08/04	09:41:04:060	Input 1	LO
Detail#02	04/08/04	09:41:04:003	Input 2	HI
Detail#03	04/07/04	15:48:03:761	DTT Input	LO
Detail#04	04/07/04	14:45:08:103	Comms Alarm	HI
Detail#05	04/07/04	13:12:08:127	Output 2	LO
Detail#06	04/06/04	08:45:07:013	Transmitter 1	HI
Detail#07	04/06/04	07:51:06:843	DTT Input	HI
Detail#08	04/06/04	05:15:05:538	RX DTT 1	HI
Detail#09	04/06/04	04:51:04:764	Comms Alarm	LO
Detail#10	04/06/04	04:48:09:567	Hardware Alarm	HI
Detail#11	04/06/04	03:27:06:685	RX DTT 1	LO
Detail#12	04/06/04	03:15:07:947	Comms Alarm	HI
Detail#13	04/05/04	14:39:08:083	Hardware Alarm	LO
Detail#14	04/05/04	14:39:09:921	Input 1	HI

Figure 2. Sequence of Events Log

Sequence of Events

Figure 2 shows the Sequence of Events directory, listing the record number, date, time, trigger label, status and color indicator. Figure 3 shows the details from event record #1.

Programmability

Logic functions can be changed or fine-tuned remotely through the GARD 8000 Teleprotection unit's TCPIP or RS-232 port.

User Programmable Logic Functions

Change timer values, logic states and logic functions without ever removing a module or opening the chassis.

User Programmable Inputs and Outputs

The 3-rack GARD 8000 System unit has 8 I/O slots in the back to house a number of communications or discrete I/O modules. All logic mapping to the inputs, outputs and communications is fully programmable to meet specific customer requirements.

Create your own alarm conditions

The GARD 8000 Teleprotection unit can be programmed to any alarm configuration desired using the outputs on the I/O modules.

Every GARD 8000 Teleprotection unit is supplied pre-programmed with either default operating logic or custom logic. It should be noted that it is standard practice for RFL to provide system programming with every unit at no charge. Figure 4 shows the parameter settings for Channel 4 of the audio-tone version.

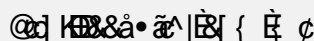

System Specifications

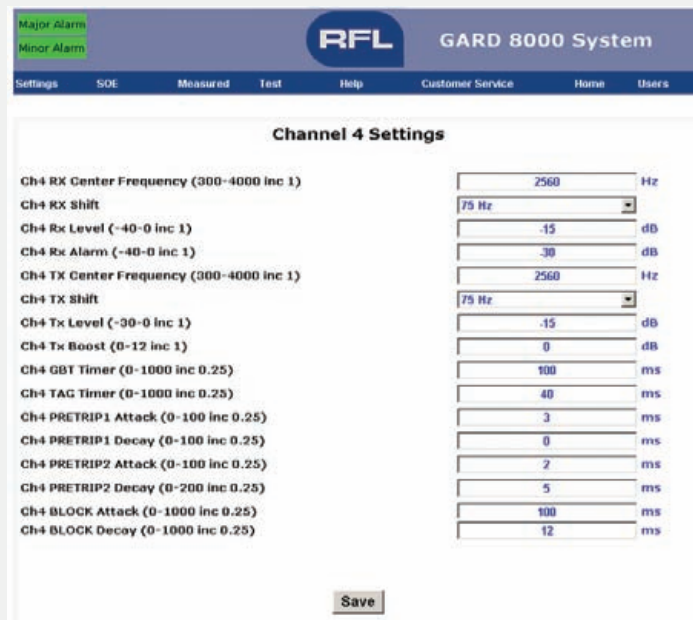

Figure 4. Channel Parameter Settings

Audio Teleprotection

The GARD 8000 audio tone teleprotection module provides four FSK transmitters/receivers. All transceivers are bidirectional and can be programmed for any operating frequency or bandwidth between 300 and 4,000 Hz. Channel one can be set to operate as a modem channel. This channel provides a communication link to the remote terminal for remote interrogation.

Channel one can also be configured to be used for bi-directional status, up to 16 points are supported. The channel can also be used to transmit RS-232 data at rates up to 300bps. When status or data is enabled, the remote interrogation feature can not be used.

Audio Interface Configurations

Single Two-Wire Terminals

Single Four-Wire Terminals

Recommended Channel Frequencies

Range: 300 Hz to 4000 Hz

Resolution: 1Hz

Transmit Level

Adjustable from -30 dBm +0 dBm in 1dB steps

Receiver Sensitivity

Minimum Input Level: -40 dBm

Maximum Input Level: 0 dBm

Receiver Dynamic Range (referenced to center point)

-17 dB to + 11 dB

Adjacent Channel Rejection

40 dB

60-Hz Rejection

A received tone at -30 dBm will not be affected by a 50 Hz or 60 Hz signal as great as 40 Vrms with optional 50/60 Hz blocking filter.

Amplitude Stability

The Transmit level will vary by no more than 31 dB.

Spurious Output

All harmonics and spurious outputs are at least 40 dB lower than the carrier.

Transmitter Stability

The transmitter frequency is stable within 0.02 percent over the full range of temperature and input power variations.

Trip Boost

Amplitude: Adjustable from zero to +12 dB in 1 dB steps.

Duration: Adjustable from zero to 30 seconds in .25ms steps.

Input and Output Impedance

600 Ohms

16 Point Bidirectional Status

Requires use of modem channel

Bandwidth 300Hz (3 150 Hz)

Transmit time: 110ms (one way)

RS-232 Data Channel

Requires use of modem channel

Bandwidth 300Hz (3 150 Hz)

Data rate: 300bps

RS-232: Software handshaking, TX, RX data

Digital Teleprotection

Each Digital TPS Engine can transfer up to 32 functions. These functions are broken down into 4 different function blocks. Each can be configured independently, and sent over the communications bus to the communications interface of choice.

Figure 5. shows a GARD 8000 with the four standard function blocks configured with three different communications interfaces.

Specifications are subject to change without notice

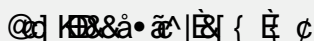

Because RFL™ and Hubbell® have a policy of continuous product improvement, we reserve the right to change designs and specifications without notice.

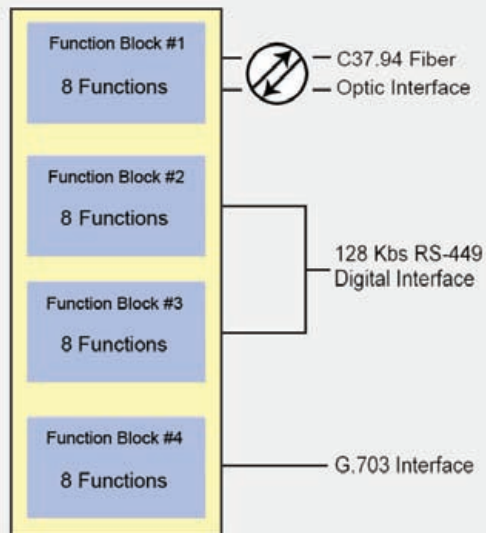

Figure 5. GARD 8000 System Diagram

Fiber Optic Communications

Fiber Optic Communications Interfaces and System Gains are as follows:

Wavelength & Emitter Type	Fiber Type	Connector Type	Output Level	Receiver Sensitivity	System Gain
1300nm LED	Singlemode	ST	-17 dBm	-39 dBm	21 dB
1300nm Laser	Singlemode	ST	0 dBm	-39 dBm	39 dB
1550nm Laser	Singlemode	ST	-3 dBm	-39 dBm	36 dB
C37.94	MM	ST	-19dBm	-32 dBm	13 dB
C37.94	SM	ST	-21.5Bm	-32 dBm	10.5 dB

* @ 25 C

Real Time Clock

IRIG-B

The GARD 8000 Teleprotection unit accepts the IRIG-B Standard Time Code on a 1kHz modulated or unmodulated carrier. Nominal signal levels are 3.3 volts peak-to-peak (3 0.5v) for a logic "1" and 1 volt peak-to-peak (3 0.2v) for a logic "0". The IRIG-B input presents a 3.7k ohm impedance and is transformer isolated.

Resolution

1 ms

Accuracy

Free Running: Within 1 minute per month
Under IRIG-B Control 31ms

Reset

Manual or by IRIG-B code

SNTP - Simple Network Timing Protocol

The GARD 8000 comes with standard support for SNTP. Settings are accessed via the web browser.

General Specifications

Events Storage

The Sequence of Events Recorder on the main controller module can store up to 600 events.

TCPIP Port

Two TCPIP ports, one on the front, one on the back.

RS-232 Interrogation Ports

The GARD 8000 Teleprotection unit provides one RS-232 Ports, located on the rear of the chassis. The rear RS-232 port is configured as a DTE Interface.

Number of Stop Bits: One

Parity: None

Flow Control: XON/XOFF

Isolation

The GARD 8000 Teleprotection unit's RS-232 ports (front and rear panel) are isolated from circuit common and chassis ground to a surge withstand level of 500 Vdc.

Input Power Requirements (EN 60834-1)

24 V	Rated	24 Vdc
	Range	19-29 Vdc
	Burden	<100W
48/125V	Rated	48/125 Vdc or 120 Vac
	Range	38-150 Vdc or 96-132 Vac
	Burden	<100W
250V	Rated	250 Vdc or 220 Vac
	Range	200-300 Vdc or 200-240 Va
	Burden	<100W

Power Supply

A single or redundant power supply can be provided depending on the reliability of the application. For example a DTT application for a higher voltage level line may demand the dependability of a redundant power supply. Note: The GARD 8000 Power Supply I/O provides two Form C alarm contacts for major and minor alarms.

Operate Time

Audio-Tone Units (average trip times - Dual-Tone System):

3 30	Hz	Shift:	26.47 ms
3 42.5	Hz	Shift:	20.57 ms
3 60	Hz	Shift:	14.78 ms
3 75	Hz	Shift:	12.65 ms
3 120	Hz	Shift:	11.05 ms
3 150	Hz	Shift:	10.12 ms
3 240	Hz	Shift:	9.22 ms

Digital and Fiber systems: 3-5 ms depending on mode of operation. "Operate Time" is defined as the time from the receipt of a command input to the response of a solid-

Specifications are subject to change without notice



Because RFL™ and Hubbell® have a policy of continuous product improvement, we reserve the right to change designs and specifications without notice.

General Specifications Continued



Pre-Trip Timer

Adjustable in 0.25 ms steps

Trip Hold Timer

Adjustable in 0.25 ms steps

Command Extend Timer

Adjustable in 0.25 ms steps

Non-Volatile Storage

All parameters relating to system operation are stored in erasable non-volatile RAM. All parameters related to event logging are stored in capacitor-backed RAM.

RFI Susceptibility

ANSI PC37.90.2 (35 Volts/Meter)
EN 60255-22-3 (RFI Class III)

Interface Dielectric Strength

All contact inputs, solid-state outputs, power supply inputs and relay outputs meet the following specifications:
ANSI C37.90-1989 (Dielectric)
ANSI C37.90.1-2002 (SWC and Fast Transient)
EN 60255-5 (1500 Vrms Breakdown Voltage and Impulse Withstand)
EN 60255-22-1 (SWC Class III)
EN 60255-22-2 (ESD Class III)
EN 60255-22-4 (Fast-Transient Class III)
EN 60834-1

Temperature

Operating: -20° C to +75° C (-4° F to +167° F)
Storage: -40° C to +85° C (-40° F to +185° F)

Relative Humidity

Up to 95 percent at +40° C (+104° F), non-condensing

Warranty Statement

RFL's standard warranty for the GARD 8000 Teleprotection unit is 10 years from date of delivery for replacement or repair of any part which fails during normal operation or service.

User Interface

Protection system reliability may be compromised by increased complexity of protection devices. While these protection devices offer added flexibility they also increase the risk for errors. Complicated settings, configurations and interconnections all combine to having an undesirable effect on protection system security and dependability.

The GARD 8000 System is designed with ease-of-use in mind. While high functionality and great detail is provided,

it is not necessary to make field configurations, if not desired. The web browser User Interface makes interaction with the device highly intuitive and handling greatly simplified.

Front Panel LEDs

Two rows of ten multi-colored LEDs provide basic event information. The LED operation is fully configurable and labels can be changed to suit the application. Custom configuration and labeling can be factory-made by RFL without extra charge. Any field modifications required are simply made by use of the browser interface.

Front Panel Display

An optional touch screen display (TSD) is available for metering, targets and settings. The TSD provides a color screen that will automatically orientate itself for horizontal or vertical mounting. User programmable buttons are provided for unique customer requirements. For things such as breaker control or cut-in/cut-out switches.

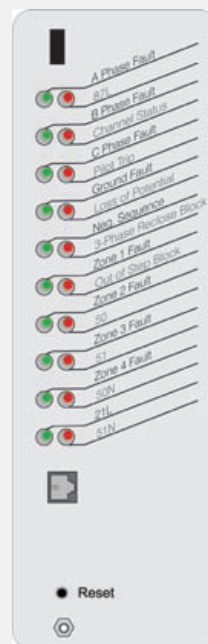
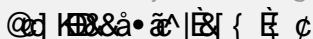

Figure 6. GARD 8000 Front Panel LEDs (6U)



Figure 7. GARD 8000 3U Front Panel

Specifications are subject to change without notice



Because RFL™ and Hubbell® have a policy of continuous product improvement, we reserve the right to change designs and specifications without notice.



Web Browser UI

All interaction with the GARD 8000 System is made by the use of a standard web browser. The web pages reside in the device; no special application software is required on the PC.

Web browser technology provides a much higher level of ease-of-use as compared to the conventional “menu-driven” operation. It is fast and simple to view device status, access diagnostic and test functions and to change settings. Emulating the operations of a standard web site, navigation is intuitive and eliminates the need to study written instructions. If preferred, the instruction manual, that also resides in the device, is simply accessed by the HELP function.

For off-line preparation of settings and configuration files, a small application program “emulating” a GARD 8000 System, which is available free of charge, can reside on the PC or local server.

A PC is connected to the front TCP/IP port with a standard connector.



Figure 9. Web Browser User Interface

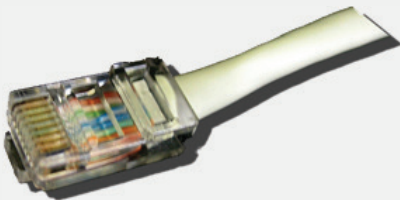

Figure 10. Ethernet Connector

Input and Output Modules

The GARD 8000 System is configured with a selectable number of input and output modules on the rear part of the chassis.

The following combinations are available for mounting in the up to 10 rear slots (6U) or 4 rear slots (3U):

- 1 communication interface/6 inputs
- 1 communication interface/6 outputs
- 6 inputs/6 inputs
- 6 inputs/6 relay outputs
- 6 inputs/6 solid state outputs
- 6 solid state outputs/6 solid state outputs
- 6 solid state outputs/6 relay outputs
- 6 relay outputs/6 relay outputs
- 4 latching relay outputs/4 form-C contacts

All relay output contacts are Form A (NO) or Form B (NC) jumper selectable. A simple setting for an inverter logic gate provides inversion for each input and output. Each input and output has a timer associated with it that has settings for both pick-up delay (input debounce, output security) and drop-out delay (pulse-stretch).

* With the exception of the latching relay module which is form-C only.

Optically Isolated Inputs

Quantity: 6 per module

Input Voltage Jumper Selectable: 24/48/125/250 Vdc

Operation Range:

- 24 Volts: 19 to 36 Vdc, Nominal Input
- 48 Volts: 37 to 68 Vdc
- 125 Volts: 94 to 150 Vdc
- 250 Volts: 189 to 300 Vdc

Input Current: 1.5 mA minimum

Minimum Pulse Width:

0.03 ms, additional debounce time set in the logic

Solid-State Outputs

Quantity: 6 per module

Output Current: Maximum 1 A continuous, 2 A for 1 minute, or 10 A for 100 msec

Open-Circuit Voltage: 300 Vdc maximum

Pick-up Time: 0 msec

Relay Output

Quantity: 6 per module

Relay Pick-up Time: 4 msec

Output Current Rating: 6 A continuous

Surge: 30 A for 200 msec

Alarm Relays

Quantity: 2

Contacts: SPDT (Form C)

Output Current: 100 mA 300 Vdc resistive load

Terminal Connections

Screw terminals for ring lugs with wire up to AWG #10.

Specifications are subject to change without notice

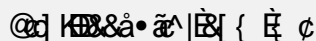

Because RFL™ and Hubbell® have a policy of continuous product improvement, we reserve the right to change designs and specifications without notice.



Native IEC-61850

The GARD 8000 complies to the requirements stated in IEC-61850-2 for teleprotection equipment. The HMI functions come standard with the GARD 8000, however, if tripping capability over a LAN is desired, the optional ethernet tripping module is required.

Ethernet Tripping Module (IEC 61850 compliant)

The GARD 8000 System can be provided with an Ethernet Tripping Module. IEC 61850 substation automation provides a LAN (Local Area Network) in the substation where trip messages are passed between the devices via GOOSE messages on a TCP/IP network.

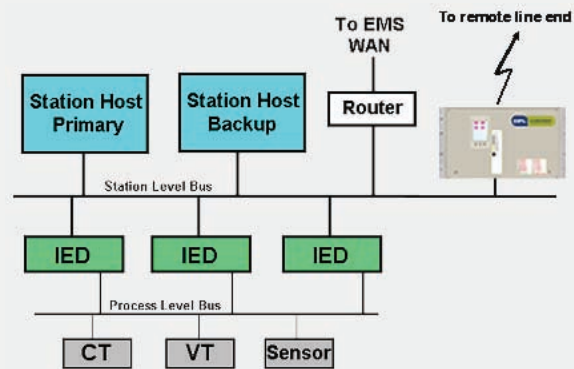

Figure 11. IEC 61850 Substation

The GOOSE message is routed to perform trip functions of circuit breakers, but a shortcoming with the network is that there is no easy means to transfer a GOOSE message to a remote location if the Ethernet network does not encompass the two substations. The GARD 8000 Ethernet trip-ping module solves this dilemma, by retrieving GOOSE messages from the LAN and transporting them over any of its communication interfaces.

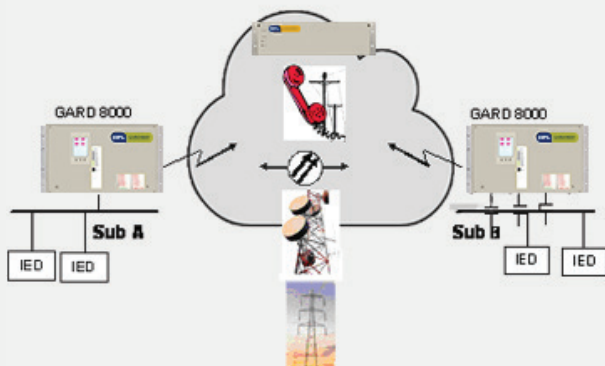

Figure 12. GARD 8000 teleprotection between two IEC 61850 substations

The GARD 8000 provides the link between two IEC 61850 substations over any communication media. The sending GARD 8000 retrieves GOOSE messages from the substation LAN, puts it on a communication link to a remote GARD 8000 that puts it on its substation LAN.

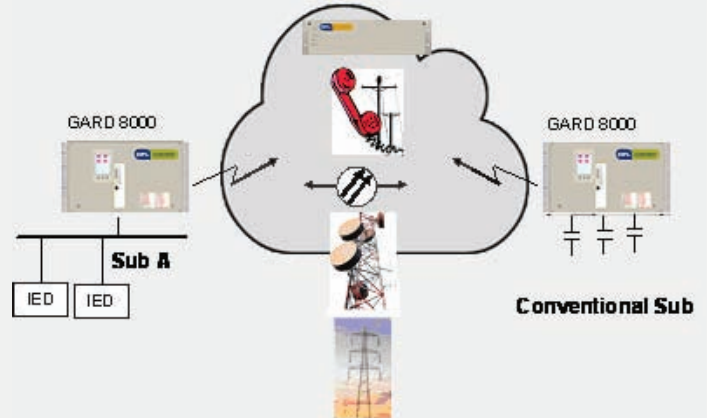

Figure 13. GARD 8000 Teleprotection between an IEC 61850 substation and a conventional substation

Generally, a new IEC 61850 substation needs to interact with a conventional substation at remote line ends. In this case, the GARD 8000 retrieves GOOSE messages for transfer trip or pilot relaying operations from the IEC 61850

substation LAN, transports them over any communication link and the remote, receiving GARD 8000 performs normal teleprotection operations such as tripping of breakers and pilot relaying signaling.

In addition, in case pilot relaying and teleprotection need to be performed over an Ethernet network between two conventional substations, a GARD 8000 at each line end can send GOOSE messages over the network for intertripping.

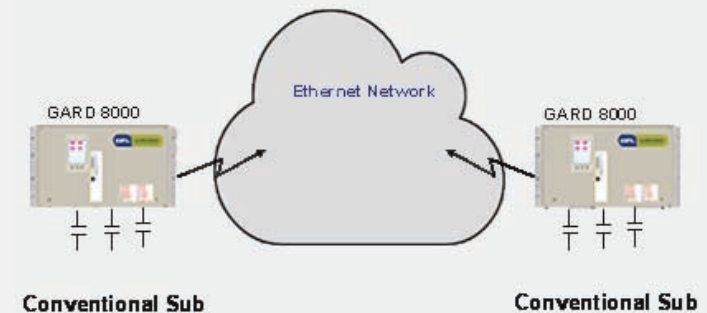
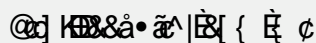

Figure 14. GARD 8000 Teleprotection over an Ethernet Network





High Capacity Status Transfer Module

The GARD 8000 standard Teleprotection System supports up to eight high-speed functions in one 64 kbps channel. For telemetry applications, there is often a need to transport a higher number of status points, but transmission time is less critical than for teleprotection signaling.

To complement the teleprotection systems, a high capacity status module is available. This module supports up to 96 status bits over a 64 kbps channel. End-to-end delay is 7-12 ms, depending on the security count used.

The high capacity status transfer module can be added as an optional front mounted module, or be supplied instead of the standard teleprotection system on the Base TPS/Display board.

Multiplexer Pass-Through Channel

The GARD 8000 has 12 built in communications channels that can be used for Teleprotection and other Protection applications. These communications channels can also be used with external devices that require a communications or pilot channel to operate. This allows the GARD 8000 Teleprotection channel to also be used as a substation multiplexer that other protective relays can be interfaced with.

The GARD 8000 can be configured with 56/64kb channels with RS-449, G.703, and C37.94 fiber optic interfaces. The unit can also be configured with a dual RS-232 communications channel for Mirrored Bit relaying or other slow speed devices. Figure 15 shows a RFL 9300 current differential relay and a Mirrored Bit relay communicating over a GARD 8000 Teleprotection channel configured with two relaying communication interfaces.

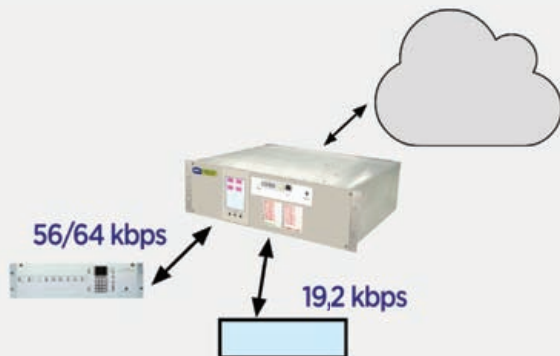

Figure 15. GARD 8000 Used as a Multiplexer

GPS Module

Accurate time stamping is essential for evaluation of protection system operations, especially following a major system disturbance.

The substation may be equipped with a GPS central clock that can be connected to the GARD 8000 IRIG-B port. When a central clock is not available, the GARD 8000 can have its own, built-in GPS receiver.

When the GARD 8000 is equipped with the internal GPS receiver, the IRIG-B port can be used to supply IRIG-B to other devices. This enables not only the GARD 8000 System to keep accurate time tags but other protective devices also have access to a dc-powered, substation hardened, time source that is independent from any centralized GPS system.

Alarm Reporting

The GARD 8000 System Platform provides three types of alarm reporting capabilities:

Programmable Contact Output

Any alarm output that is defined in the system logic can be programmed to a user defined output. You can have as many outputs as needed for alarm requirements. The GARD 8000 alarm configuration page allows the user to program system level Minor or Major alarms. When a Minor or Major alarm is triggered an output will be initialized on the unit.

DNP3

The GARD 8000 can broadcast DNP3 message through the Ethernet port or the integrated RS-485 port to support DNP masters along with solicited or unsolicited messages.

SNMP

The GARD 8000 can generate SNMP V2C traps in the event of an alarm condition. The alarm traps are programmable. The GARD 8000 has HMI Output bits which can be defined by the user to refer anything in the system logic. This includes alarms and trip inputs/outputs. By using the built in web interface, each HMI output can be assigned a text label by the user. If an alarm event occurs a trap will be generated and will include the version number (V2C Notification), the RFL OID and the "timestamp".

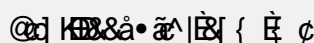

Examples of GARD 8000 System Configurations

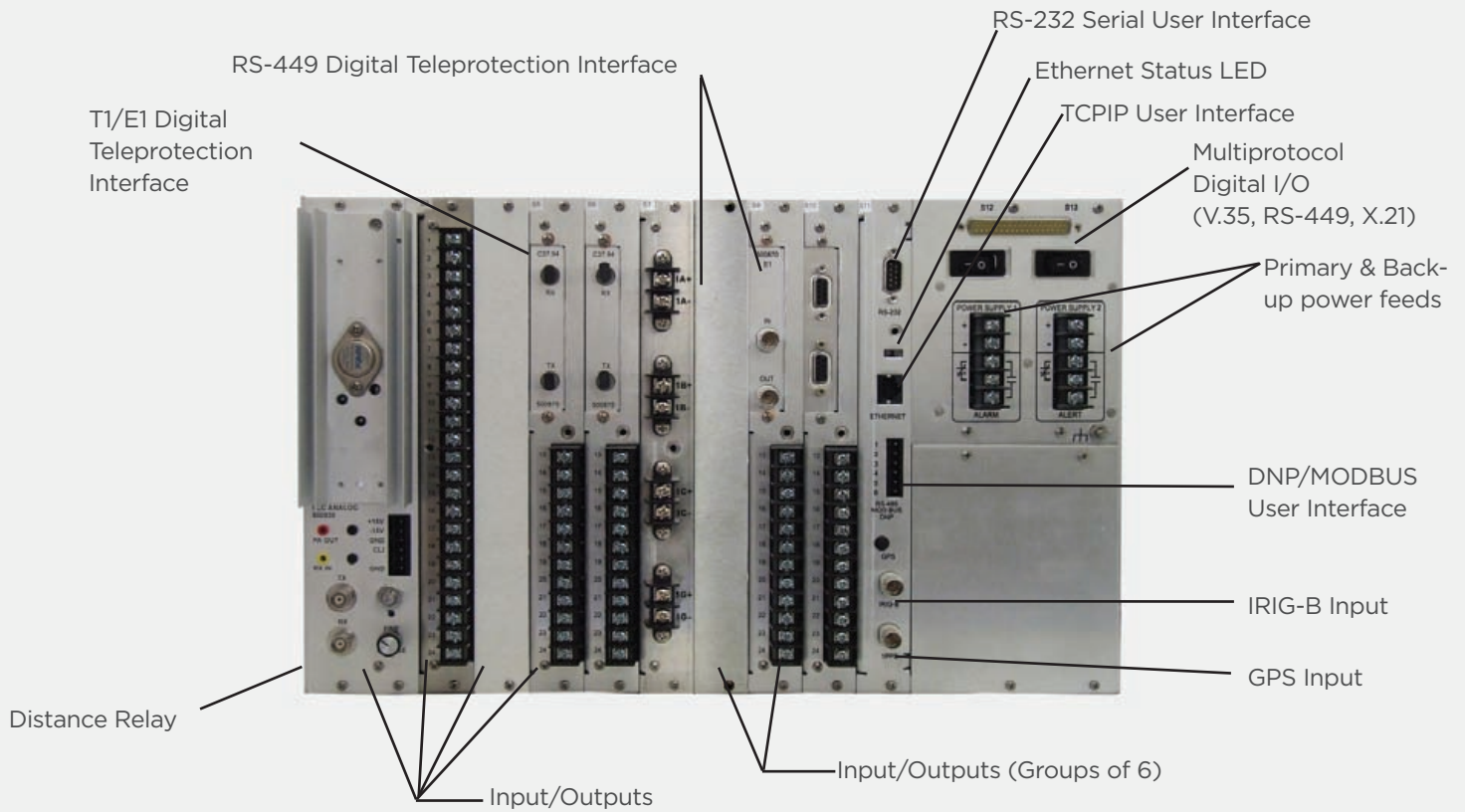

Figure 16. Rear View 6U GARD 8000 Digital Protection System with (4) Digital Interfaces

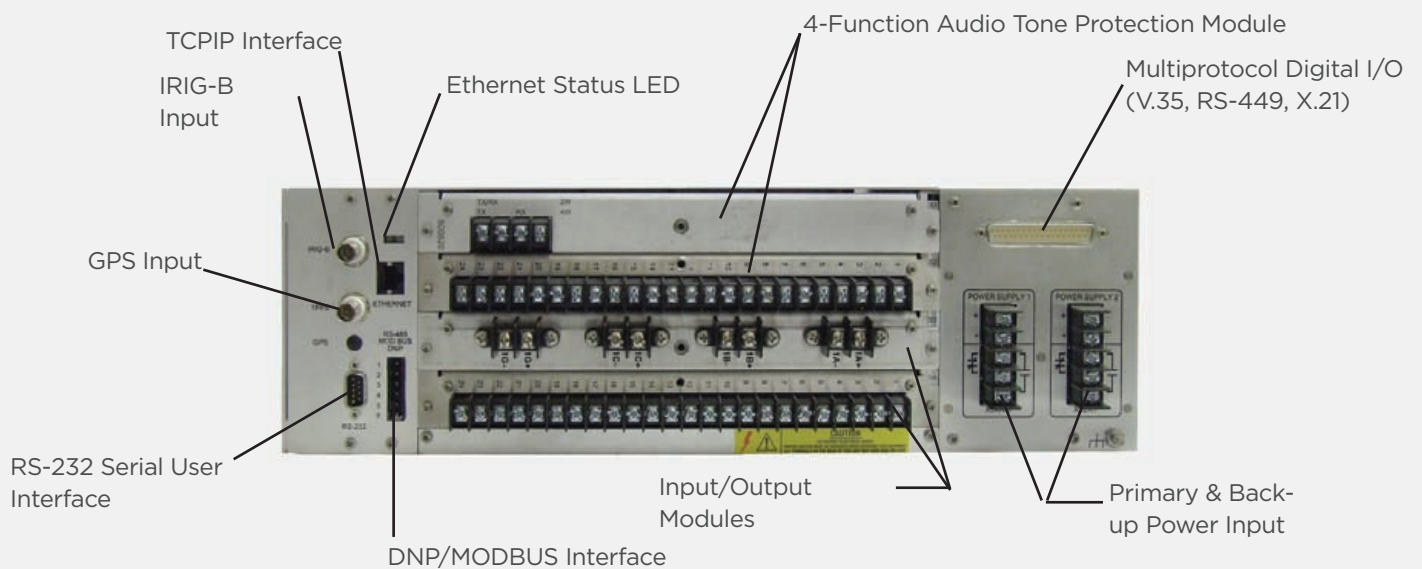
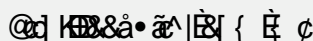

Figure 17. Rear View 3U GARD 8000 Dual Analog Protection System.



Because RFL™ and Hubbell® have a policy of continuous product improvement, we reserve the right to change designs and specifications without notice.



GARD 8000 Single Function PLC 3U System Dimensions



Figure 11. Rack or Cabinet Mounting (3U)

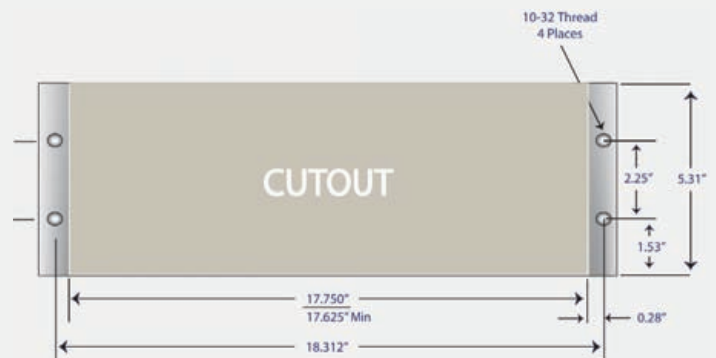

Figure 12. Panel Mounting (3U)

6U System Dimensions

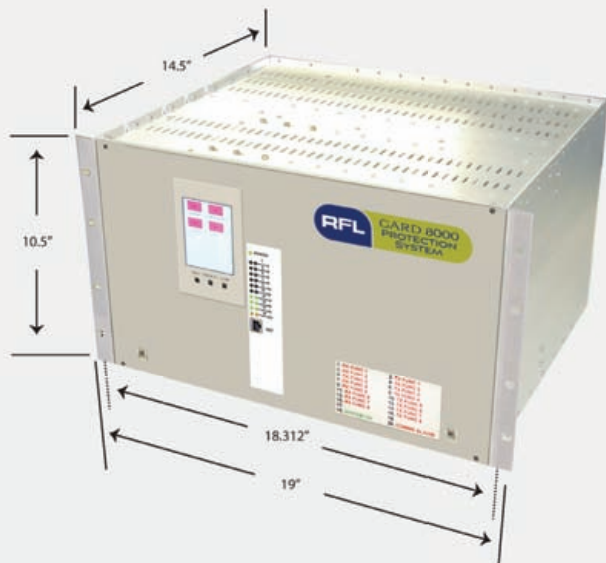

Figure 13. Rack or cabinet Mounting (6U)

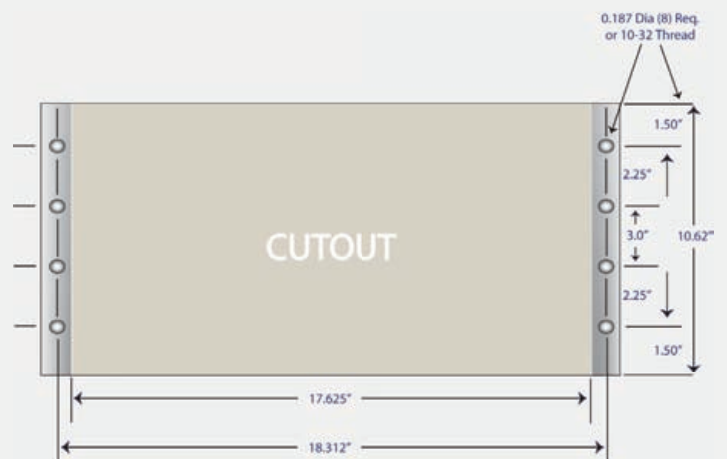
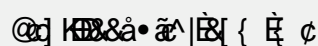

Figure 14. Panel Mounting (6U)



© 2013 Hubbell Incorporated



Because RFL™ and Hubbell® have a policy of continuous product improvement, we reserve the right to change designs and specifications without notice.



© 2013 Hubbell Incorporated

Because RFL™ and Hubbell® have a policy of continuous product improvement, we reserve the right to change designs and specifications without notice.



© 2013 RFL Electronics Inc. All rights reserved.



RFL Electronics Inc.
353 Powerville Road
Boonton, NJ 07005, USA

Tel: 973.334.3100
Fax: 973.334.3863
www.rflect.com

RFL GARD TPC

Because RFL™ and Hubbell® have a policy of continuous product improvement, we reserve the right to change designs and specifications without notice.

April 2013